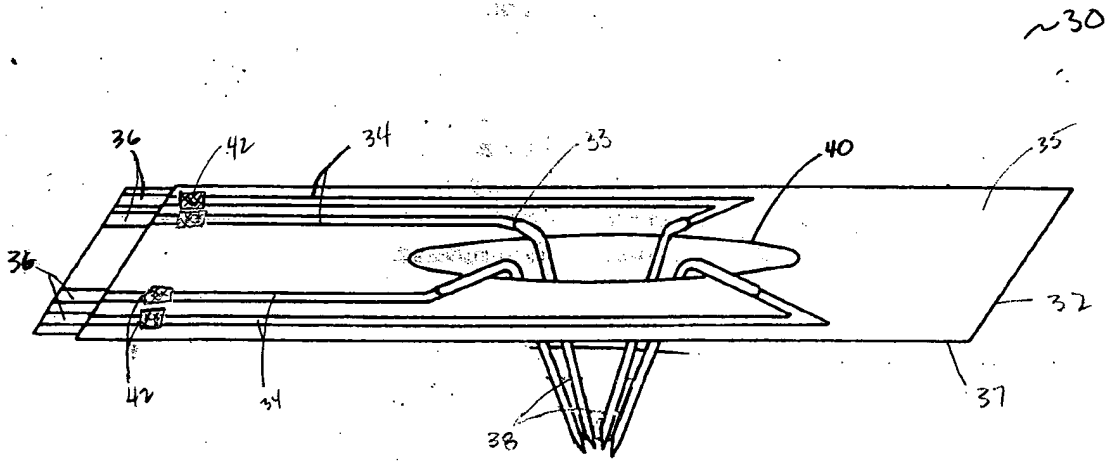

FIG. 1



FOR OFFICIAL USE ONLY

FIG. 2

~30

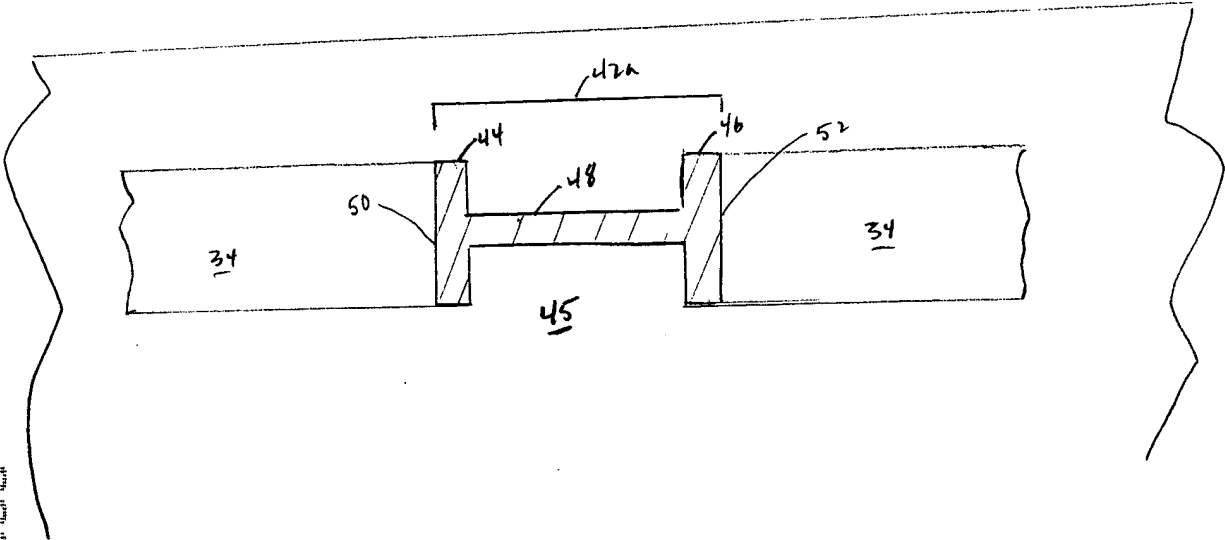

FIG. 3

~30

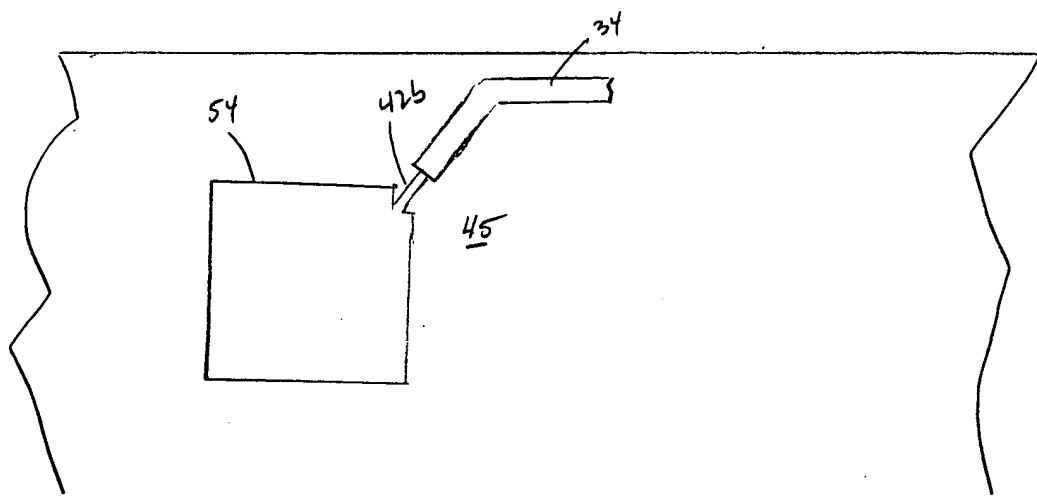
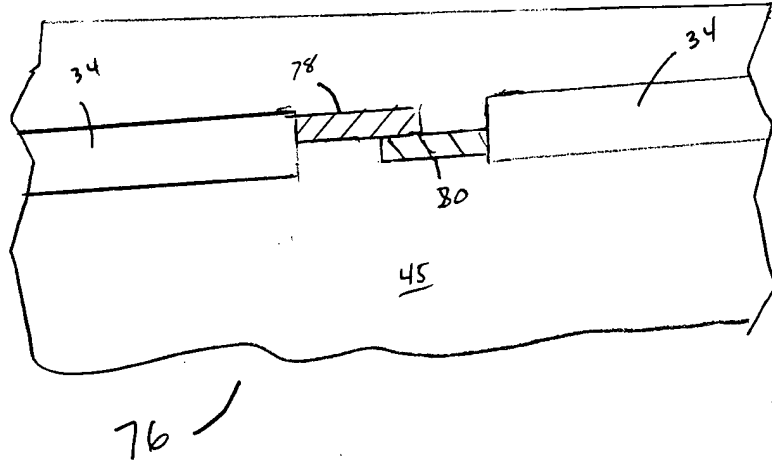

FIG. 2



FIG. 5A

~ 30



FOR INFORMATION

FIG. 5b

~ 30

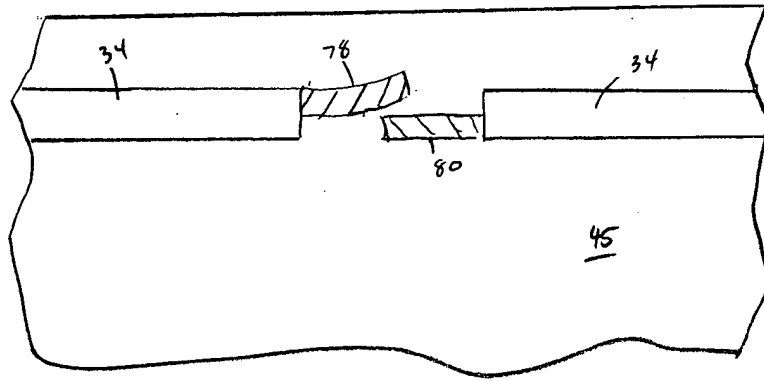

76 —

Patented 6-23-60

FIG. 6A

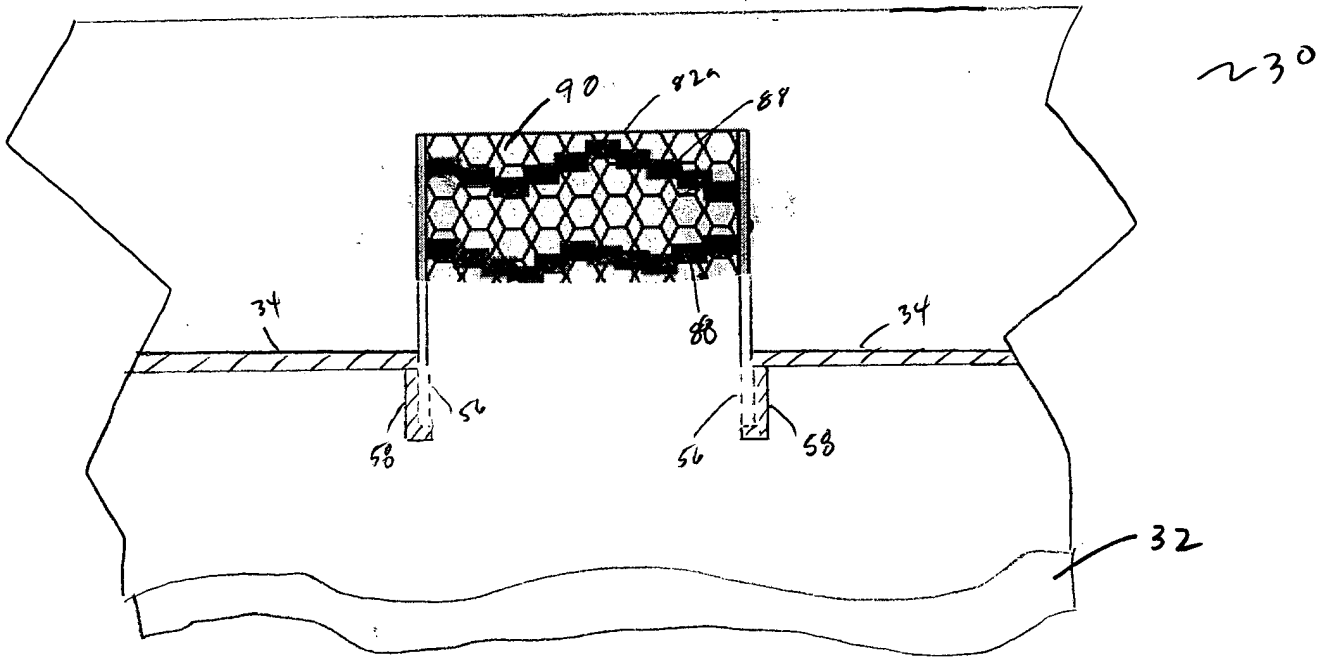

FIG. 6B

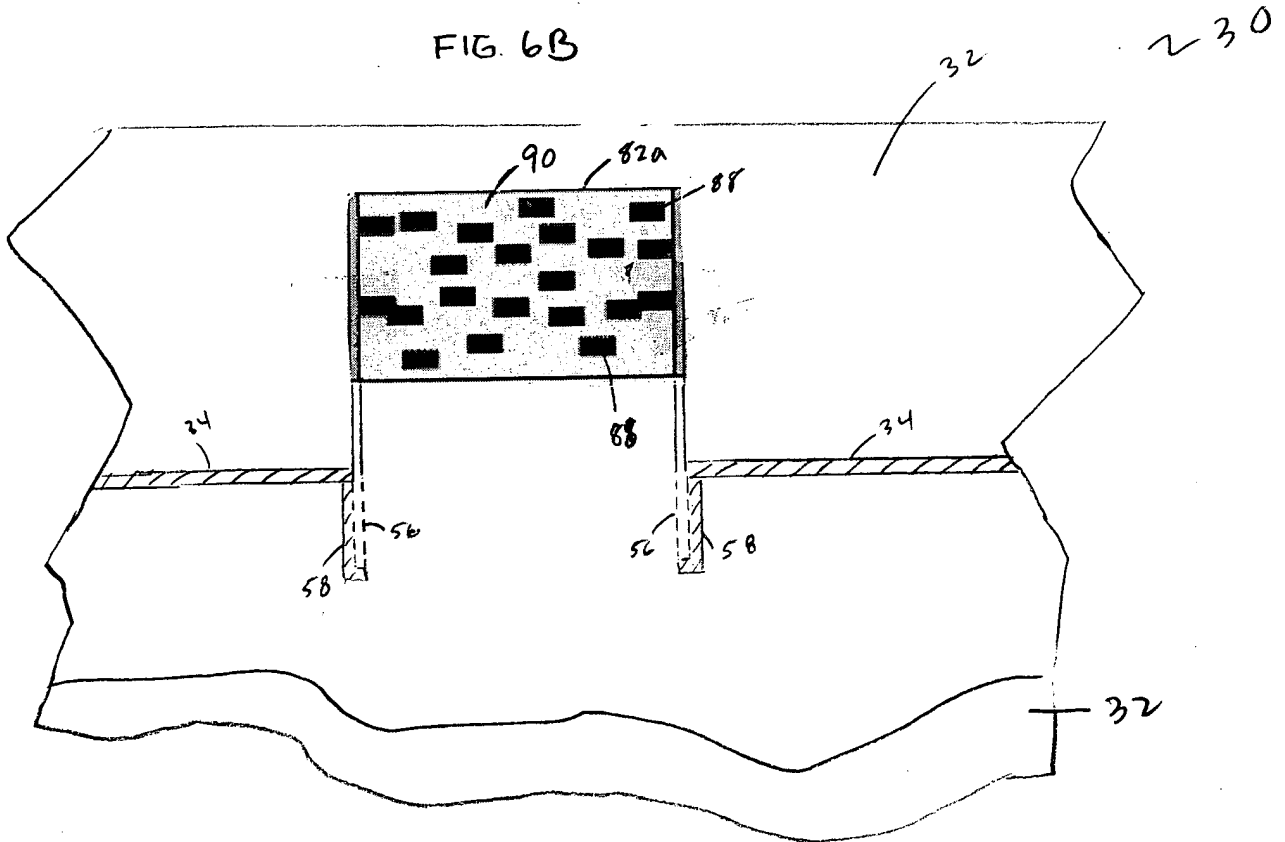

FIG. 6A

FIG. 6C

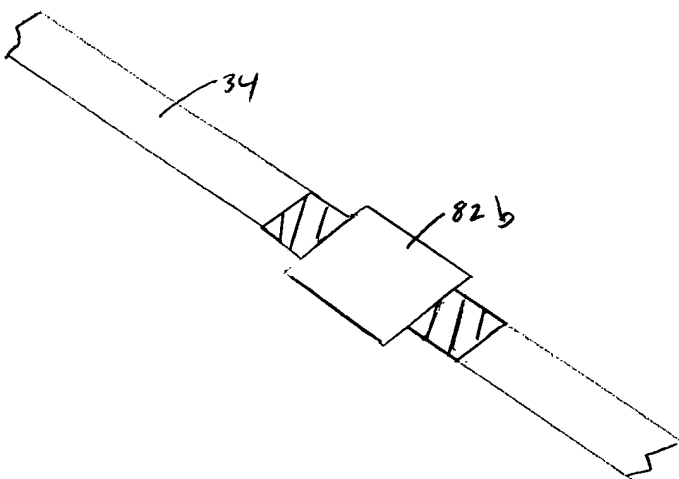
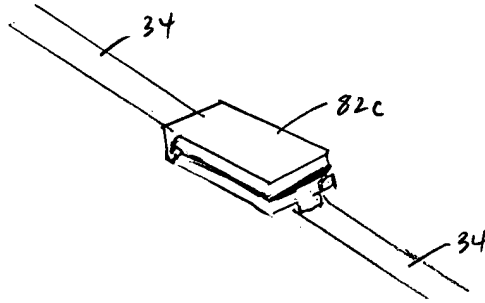

FIG. 6C

FIG 6D



FOR S. O. 638366



FIG. 7

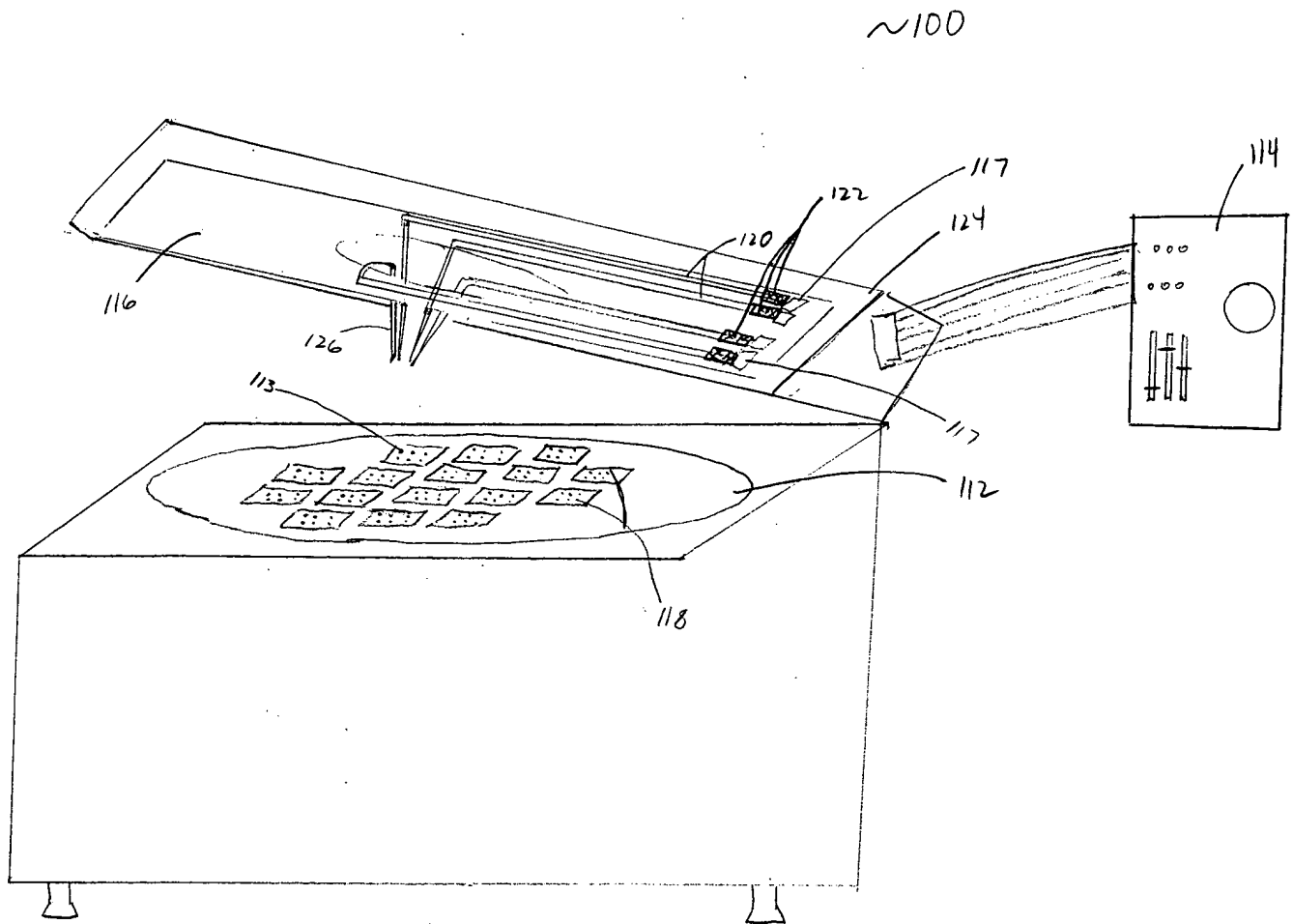
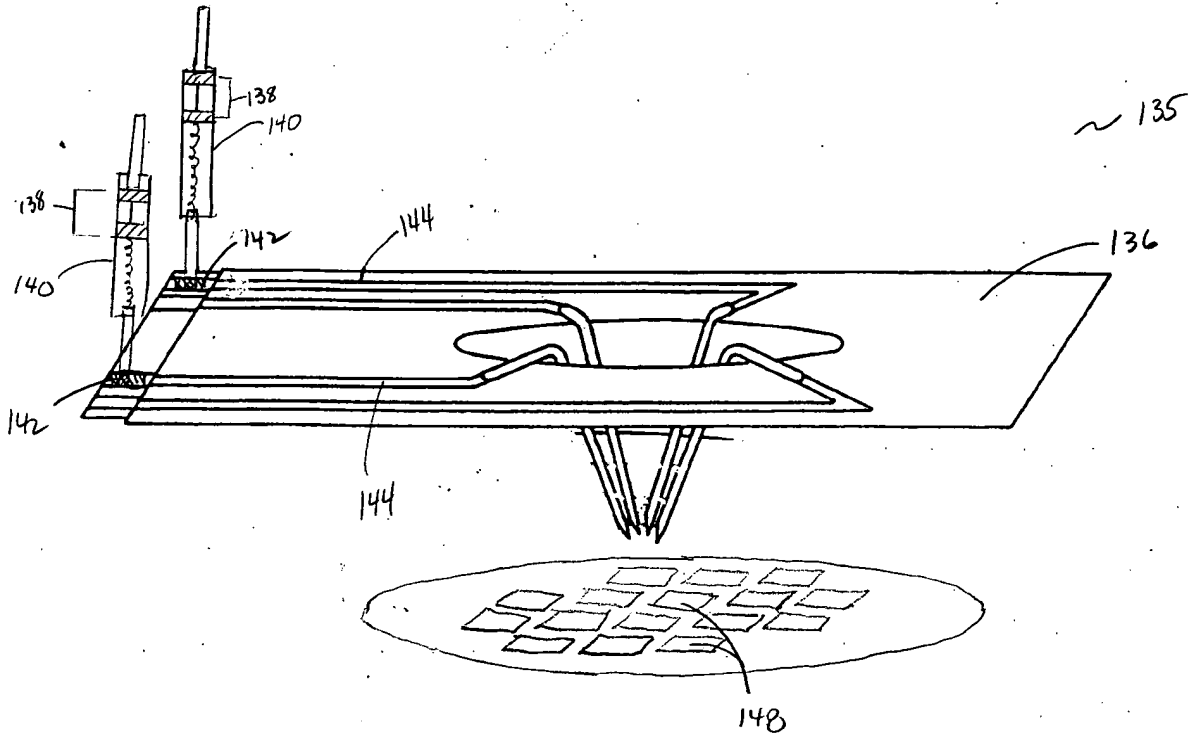

FIG. 7

FIG. 8



FOR "SECRET"

FIG. 9

~150

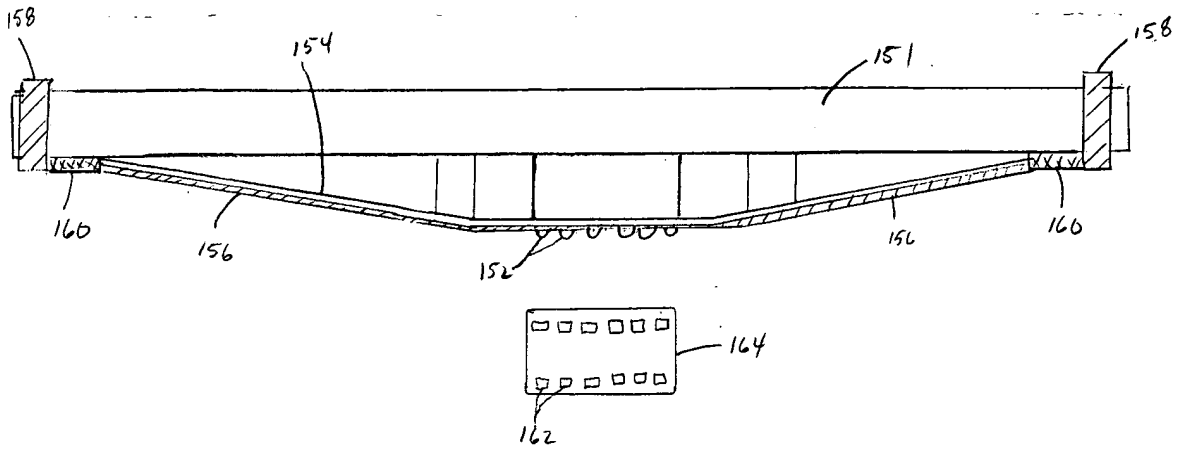

FOR PUBLICATION